

VCD *Volume Control Damper*

MVCD *Motorized Volume Control Damper*





Introduction

With its opposed blade operation closing system, Prudent Aire Volume Control Damper are designed for controlling air flow and pressure in HVAC systems. Designed to operate with opposed blade action (providing better aerodynamics), volume control damper provides better balancing control or airflow rates.

Blades are formed from single skin construction with grooved blade tips to produce an interlocking blade closure, either via manual or automatic operation.

Manually operated dampers are supplied as standard with a lockable quadrant assemble, thus allowing for conversion to motor operation without the need for additional components.

CONSTRUCTIONS & MATERIALS

- Triple V-Groove Opposed Blade operation
- Available in manual or motorized models
- Actuation available in following configurations:
 - i) Hand locking quadrant arm
 - ii) Worm gear drive
 - iii) Bare shaft
 - iv) Factory installed actuator
- Damper sizing:
 - i) Minimum size : 100 x 100 mm
 - ii) Maximum size : 2350 x 1450 mm = 1 module

Construction Available



Stainless Steel

Frame Construction



Galvanised Steel (Size Dependant)

Blade Construction



Galvanised Steel (Size Dependant)

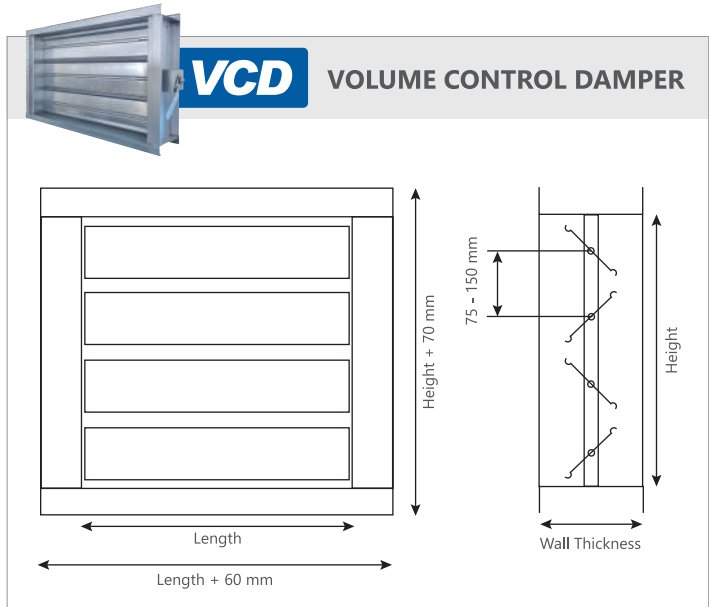

MVCD

MOTORIZED VOLUME CONTROL DAMPER - ACTUATOR LOCATION

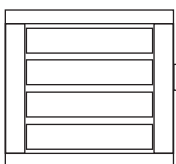

Configuration A
Shaft Outside

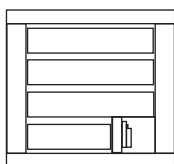

Configuration B
Inside Bottom

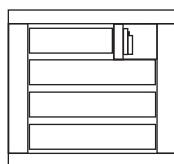

Configuration C
Inside Top

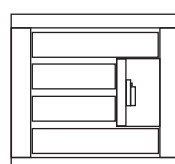

Configuration D
Inside Middle

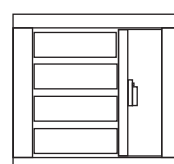

Configuration E
Compartment

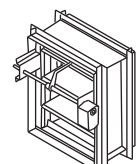

Configuration F
Infront Shaft

AERODYNAMIC PERFORMANCE

STATIC PRESSURE DROP

PRESSURE DROP VS DUCT VELOCITY

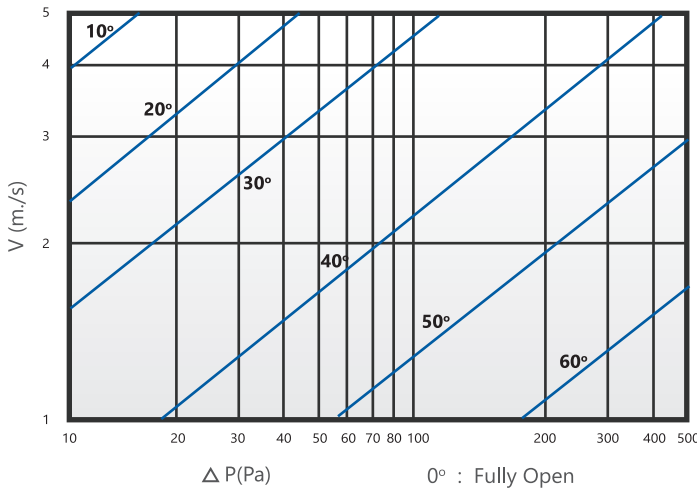

V Duct Velocity (m/s)
ΔP Static Pressure Drop (Pa)
 00, 100, 200, ... etc Degree Opening
 Max static pressure drop for fully open dampers is 10 Pa

CLOSED DAMPER LEAKAGE

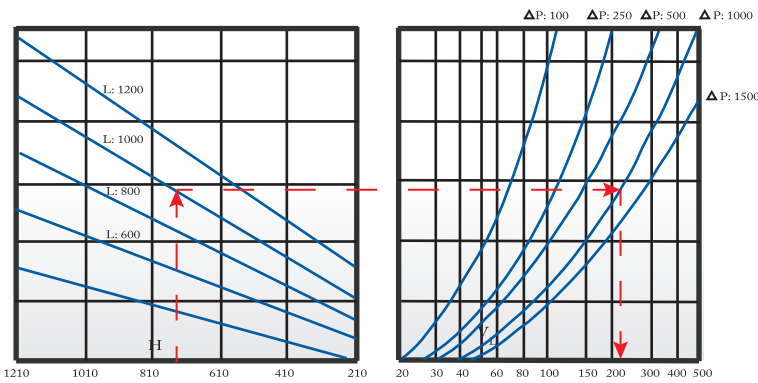

OPERATION RANGE

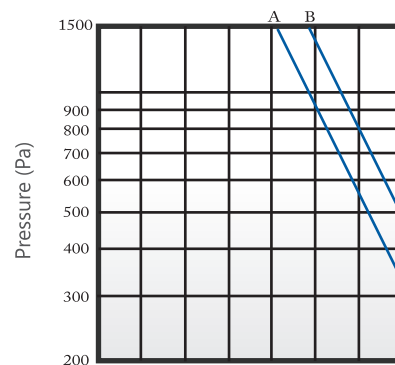

L Length (mm) **VL** Volume Flowrate (cmh) **A** Recommended operation range
H Height (mm) **ΔP** Pressure Difference (Pa) **B** Critical operation range

ACTUATOR TORQUE REQUIREMENTS

FOR PRESSURE LESS OR EQUAL TO 500 PA

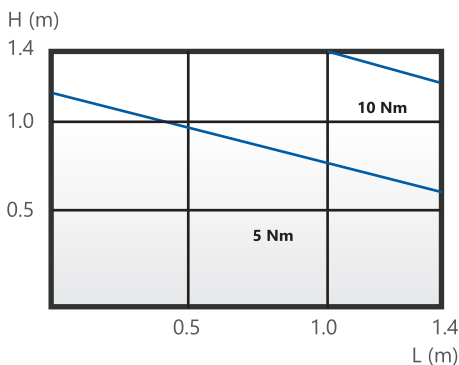

FOR PRESSURE LESS OR EQUAL TO 1000 PA

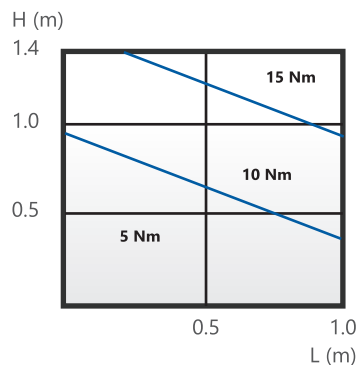

H Damper Height (m)
L Damper Length (m)

JOINING METHODS

Angle Joint



**1 Side Angle Joint
1 Side Grille**



TDC Joint



**1 Side TDC Joint
1 Side Grille**



Slot In Type



**1 Side Flat
1 Side Grille**



Slip Joint

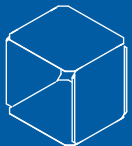

VOLUME CONTROL DAMPER TECHNICAL SPECIFICATION

Casing Assembly

1. 0.8mm - 1.5mm thick casing section. Casing section to be welded externally with welding beads to be ground flush. Multiple modular to be provided for damper larger than 2350mm length x 1450mm height. Standard wall thickness to be 1.50mm, unless otherwise stated.
2. Standard joining method to be in TDC joint, unless otherwise stated.
3. Material provided to be galvanized steel, unless otherwise stated.

Damper Blade Assembly

1. 0.8mm - 1.5mm thick single skin configuration. The individual blade to be in triple V-grooves design. Blade operation to be of opposed blade action with linkage system. Parallel blade action configuration to be available upon request. 11.0mm galvanized steel shaft to be provided for each blade section.
2. Mechanical bushing to be tight-fitted into the casing channel sections of the casing assembly to support and maintain the blade shafts in the pre-determined locations.
3. Damper blade to be operated by quadrant arm, worm gear and electrical actuator are available upon request.
4. Material provided to be galvanized steel, unless otherwise stated.

Linkage Assembly

1. 15.0mm x 3.0mm thick linkage system to be welded to the driving blade shaft. Individual linkage components to be secured with pins or welding method at pre-determined geometry locations to ensure accurate blade phasing.

Linkage Cover & Side Seals

1. 1.5mm pre-formed angles to be welded to the damper casing assembly to provide both blade stop and sealing functions.
2. Damper side seals are available upon request.
3. Actuator mounting angles to be provided when required to ensure proper actuator mounting. Construction design to be changed according to actuator type.
4. Material provided to be galvanized steel, unless otherwise stated.

Finishing

1. Damper assembly to be in natural finish of the material.

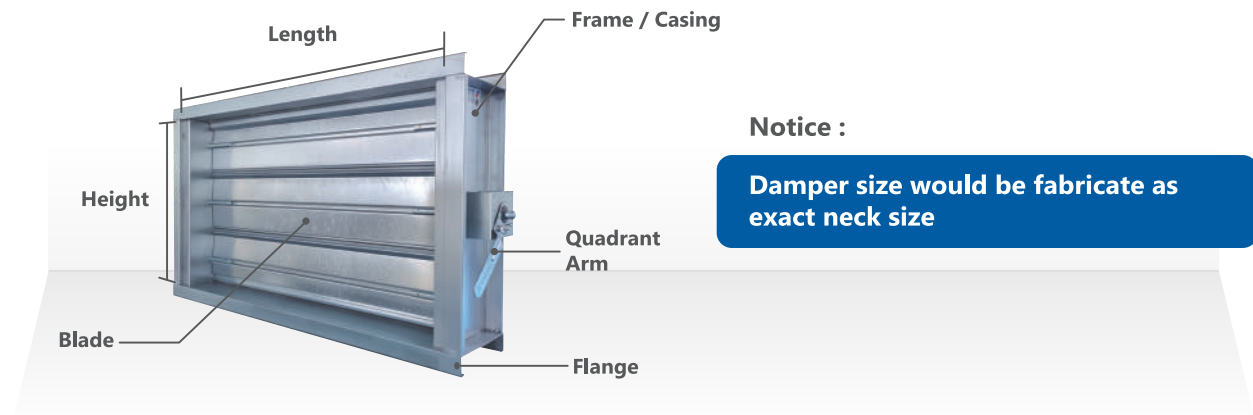

AVAILABLE TYPES



Quadrant Arm



Worm Gear









Motorized



VCD | *Volume Control Damper*

MVCD | *Motorized Volume Control Damper*

Products Range

- Grilles 
- Diffusers 
- Dampers  ◀
- Fire & Smoke Protection 
- VAV 
- Others 
- Accessories 



Prudent Aire Engineering Sdn Bhd ^{657301-P}
 Lot 2102, Jalan KPB12, Off Jalan Suria Park 1, Kg Baru Balakong,
 43300 Seri Kembangan, Selangor Darul Ehsan, Malaysia
 Tel : +603-9100 3858 (HL) / 9101 3869 / 9101 5868
 Fax : +603-9100 4868 Email : sales@prudentaire.com

www.prudentaire.com