

PROJECT TITLE : _____
 OWNER : _____
 CONSULTANT : _____
 CONTRACTOR : _____
 LOCATION : _____

PRODUCT SUBMISSION

DETAIL

Doc No.: 2024-SUB-007
 (updated on 12-04-2024)

BRAND : PRUDENT AIRE

PRODCUT DETAIL: SINGLE DEFLECTION GRILLE (MODEL: SD)

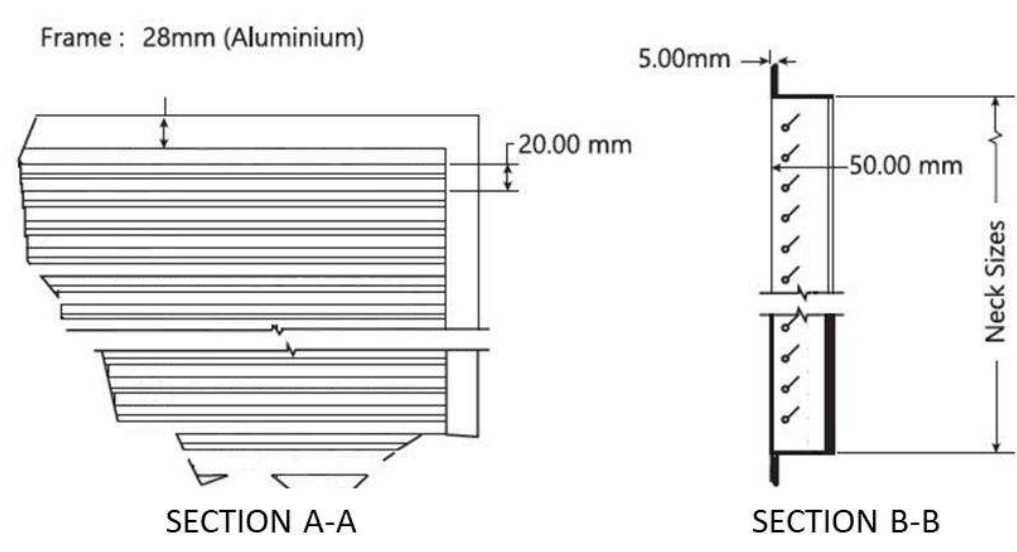
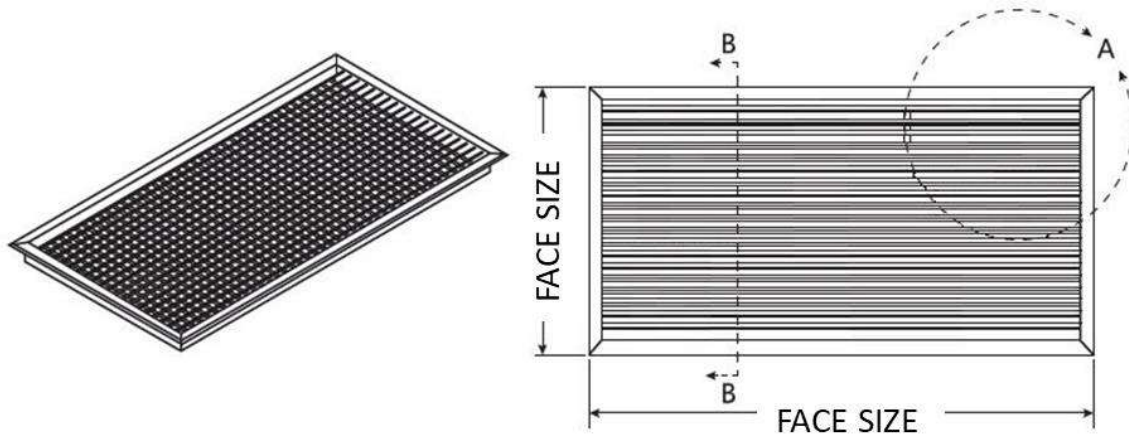

NOTES:

1. Dimension Detail
 - a. Frame:
 - Size : 28mm (30mm)
 - Thickness : 1.2mm
 - b. Deflector:
 - Shape : Aerofoil
 - Thickness : 1.0mm

Material

Color

Accessories

- | | | |
|--|--|---|
| <input type="checkbox"/> Aluminium [Standard] | <input type="checkbox"/> White (RAL 9010) [Standard] | <input type="checkbox"/> Opposed Blade Damper (OBD) |
| <input type="checkbox"/> Stainless Steel (SS304 / SS316) | <input type="checkbox"/> Others, _____ | <input type="checkbox"/> Adaptor Collar (ADR) |
| | | <input type="checkbox"/> Plenum Box c/w Wingnut Damper (PB) |
| | | <input type="checkbox"/> Others, _____ |