

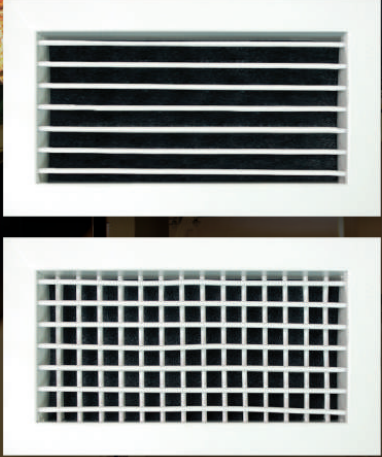

**SD DD** *Single & Double  
Deflection Grille*





## Introduction

Equipped with both horizontal or/and vertical deflection blades, Prudent Aire Deflection Grilles (Single & Double Deflection, SD/DD) are able to have adjustable flow pattern and throw length and thus providing the required air diffusion pattern (Double Deflection) and exhaust/return applications (Single Deflection).

Both horizontal and vertical blades adjustments are done manually easily without compromising the firmness of blade positions.

Adjustable flow pattern and throw length are achieved with horizontal blades directing the flow pattern and vertical blades adjusting throw length and jet width.

## CONSTRUCTIONS & MATERIALS

- Standard 86% (SD) & 74% (DD) free area
- Vanes pitch of 20mm
- Grille sizing:
  - i) Minimum size: BS.150mm x 150mm
  - ii) Maximum size: BS.3000mm x 1400mm
- Stainless steel construction available

### Frames



Extruded Aluminium



Galvanized Steel

### Vanes



Extruded Aluminium

### Surface Finishing



White (Matt)  
Customizable Color



White (Matt)

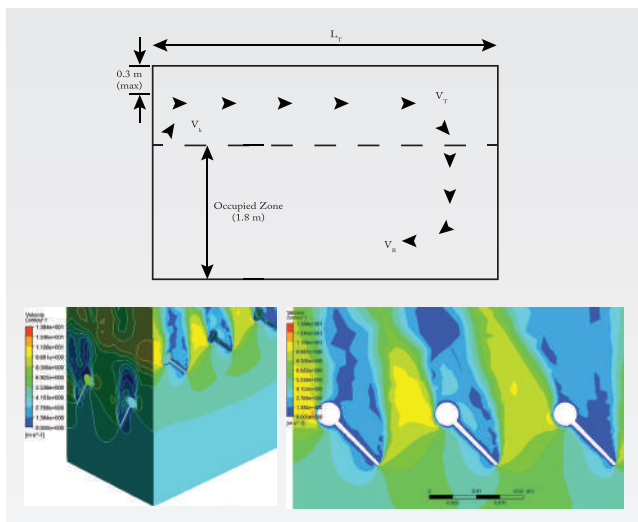

## DIMENSIONS

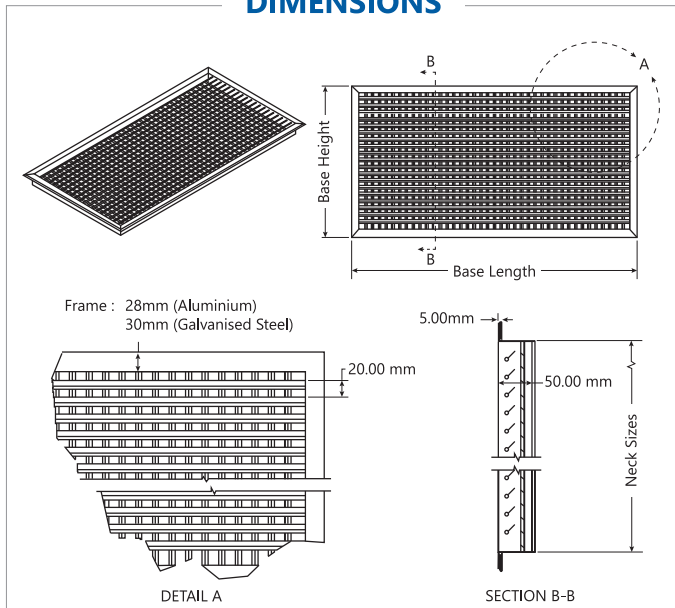

### Correction Factors

Conditions	15° Deflection	20° Deflection	40° Deflection
Effective Area (m <sup>2</sup> )	x 0.95	x 0.87	x 0.80
V <sub>K</sub>	x 1.05	x 1.15	x 1.25
Pressure Lost(Pa)	+ 1.0	+ 1.1	+ 1.2
NR	+ 0	+ 3	+ 5
L <sub>T</sub> (m)	x 0.95	x 0.85	x 0.75
Induction Ratio, i	x 1.1	x 1.4	x 2
Temperature Quotient	x 1.1	x 1.4	x 2
Ceiling Distance(>0.9m)	L <sub>T</sub> x 0.75	L <sub>T</sub> x 0.75	L <sub>T</sub> x 0.75

**TECHNICAL PERFORMANCE DATA**

**Supply (Double Deflection Grille)**

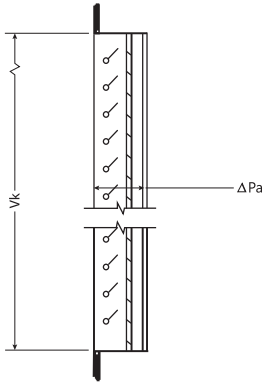

\* Diffuser performance data factored in 0° deflection, coanda effect & fully opened Radial OBD conditions.

\* The effective area given is to the best estimation & knowledge of Prudentaire's engineers at the point of entry.

Grille Neck Size, mm	Neck Area (Eff. Area) m <sup>2</sup>	Unit Volume Flowrate, m <sup>3</sup> /hr Unit Volume Flowrate, l/s	NR25		NR35		NR40		NR45		
			250 70	500 140	800 224	1000 280	1400 392	1600 448	2000 560	2500 588	3000 840
200 x 200	0.04 (0.016)	Throw Distance (0.25 m/s), m	5.5	11	16	-	-	-	-	-	-
		Face Velocity, m/s	4.3	8.7	13.9	-	-	-	-	-	-
		Total Pressure Loss, Pa	12.5	55	>80	-	-	-	-	-	-
		Noise Rating (NR)	20	42	>50	-	-	-	-	-	-
		Temperature Quotient Induction Ratio	0.15 12	0.075 >20	-	-	-	-	-	-	-
200 x 500	0.10 (0.052)	Throw Distance (0.25 m/s), m	-	6.0	9.5	11.5	16	19	34	-	-
		Face Velocity, m/s	-	2.7	4.4	5.4	7.6	8.7	10.9	-	-
		Total Pressure Loss, Pa	-	5.5	12.5	22	45	55	>80	-	-
		Noise Rating (NR)	-	<20	25	33	44	49	>50	-	-
		Temperature Quotient Induction Ratio	-	0.24 7.8	0.15 12	12.2 14.5	-	-	-	-	-

Grille Neck Size, mm	Neck Area (Eff. Area) m <sup>2</sup>	Unit Volume Flowrate, m <sup>3</sup> /hr Unit Volume Flowrate, l/s	NR25		NR35		NR40		NR45		
			250 70	500 140	800 224	1000 280	1400 392	1600 448	2000 560	2500 588	3000 840
300 x 300	0.09 (0.039)	Throw Distance (0.25 m/s), m	-	7.0	11	13	17	23	-	-	-
		Face Velocity, m/s	-	3.6	5.7	7.1	10.0	11.4	-	-	-
		Total Pressure Loss, Pa	-	10	23	38	78	>80	-	-	-
		Noise Rating (NR)	-	<20	32	37	48	>50	-	-	-
		Temperature Quotient Induction Ratio	-	0.18 10	0.115 16	0.095 18.5	-	-	-	-	-
300 x 800	0.24 (0.113)	Throw Distance (0.25 m/s), m	-	-	6.0	7.0	11	13	15	18	30
		Face Velocity, m/s	-	-	2.0	2.5	3.4	3.9	4.9	6.1	7.4
		Total Pressure Loss, Pa	-	-	3.0	4.5	9.0	12	17	27	45
		Noise Rating (NR)	-	-	<10	<20	18	23	30	37	42
		Temperature Quotient Induction Ratio	-	-	0.34 5.4	0.27 6.2	0.18 10	0.15 12	0.13 13.5	-	-
300 x 1200	0.36 (0.174)	Throw Distance (0.25 m/s), m	-	-	-	-	8.8	11	13	16	18
		Face Velocity, m/s	-	-	-	-	2.2	2.5	3.1	3.9	4.7
		Total Pressure Loss, Pa	-	-	-	-	3.5	4.5	7.0	11.5	16
		Noise Rating (NR)	-	-	-	-	<10	<20	18	27	31
		Temperature Quotient Induction Ratio	-	-	-	-	0.3 6.5	0.23 8.0	0.19 9.5	-	-

**Supply (Double Deflection Grille)**

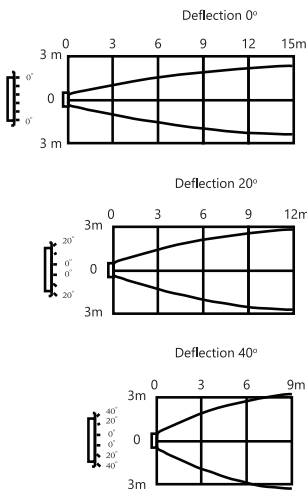

Grille Neck Size, mm	Neck Area (Eff. Area) m <sup>2</sup>	Unit Volume Flowrate, m <sup>3</sup> /hr Unit Volume Flowrate, l/s	NR25		NR35		NR40		NR50		
			250 70	500 140	800 224	1000 280	1400 392	1600 448	2000 560	2500 588	3000 840
400 x 400	0.16 (0.084)	Throw Distance (0.25 m/s), m	-	-	7.5	9.0	13	16	18	34	33
		Face Velocity, m/s	-	-	2.6	3.3	4.6	5.3	6.6	8.3	9.9
		Total Pressure Loss, Pa	-	-	5.0	7.5	15	20	30	50	78
		Noise Rating (NR)	-	-	<20	19	32	37	42	50	>50
		Temperature Quotient Induction Ratio	-	-	0.22 7.5	0.2 9.2	0.14 13	-	-	-	-
400 x 800	0.32 (0.174)	Throw Distance (0.25 m/s), m	-	-	-	6.2	9.8	11	13	17	19
		Face Velocity, m/s	-	-	-	1.6	2.2	2.5	3.1	3.9	4.7
		Total Pressure Loss, Pa	-	-	-	<2	3.5	4.5	7.2	11	17
		Noise Rating (NR)	-	-	-	<10	<20	18	23	31	35
		Temperature Quotient Induction Ratio	-	-	-	0.5 4.5	0.27 7.0	0.22 8.0	0.19 9.5	-	-
400 x 1200	0.48 (0.258)	Throw Distance (0.25 m/s), m	-	-	-	-	-	8.5	11	13	16
		Face Velocity, m/s	-	-	-	-	-	1.6	2.1	2.6	3.1
		Total Pressure Loss, Pa	-	-	-	-	-	<3	3.1	5.0	7.0
		Noise Rating (NR)	-	-	-	-	-	<10	<20	18	22
		Temperature Quotient Induction Ratio	-	-	-	-	-	0.37 5.5	0.28 7.2	0.24 8.5	-

Grille Neck Size, mm	Neck Area (Eff. Area) m <sup>2</sup>	Unit Volume Flowrate, m <sup>3</sup> /hr Unit Volume Flowrate, l/s	NR25		NR35		NR40		NR50		
			250 70	500 140	800 224	1000 280	1400 392	1600 448	2000 560	2500 588	3000 840
500 x 500	0.25 (0.143)	Throw Distance (0.25 m/s), m	-	-	6.0	7.0	11	13	15	18	30
		Face Velocity, m/s	-	-	1.5	1.9	2.7	3.1	3.8	4.8	5.7
		Total Pressure Loss, Pa	-	-	<3	<3	5.0	6.5	10	16	24
		Noise Rating (NR)	-	-	<10	<20	18	23	30	37	42
		Temperature Quotient Induction Ratio	-	-	0.34 5.4	0.27 6.2	0.18 10	0.15 12	0.13 13.5	-	-
500 x 1200	0.60 (0.365)	Throw Distance (0.25 m/s), m	-	-	-	-	-	-	-	-	14
		Face Velocity, m/s	-	-	-	-	-	-	-	-	2.3
		Total Pressure Loss, Pa	-	-	-	-	-	-	-	-	3.5
		Noise Rating (NR)	-	-	-	-	-	-	-	-	<20
		Temperature Quotient Induction Ratio	-	-	-	-	-	-	-	-	0.09 7.0

## Drop Correction

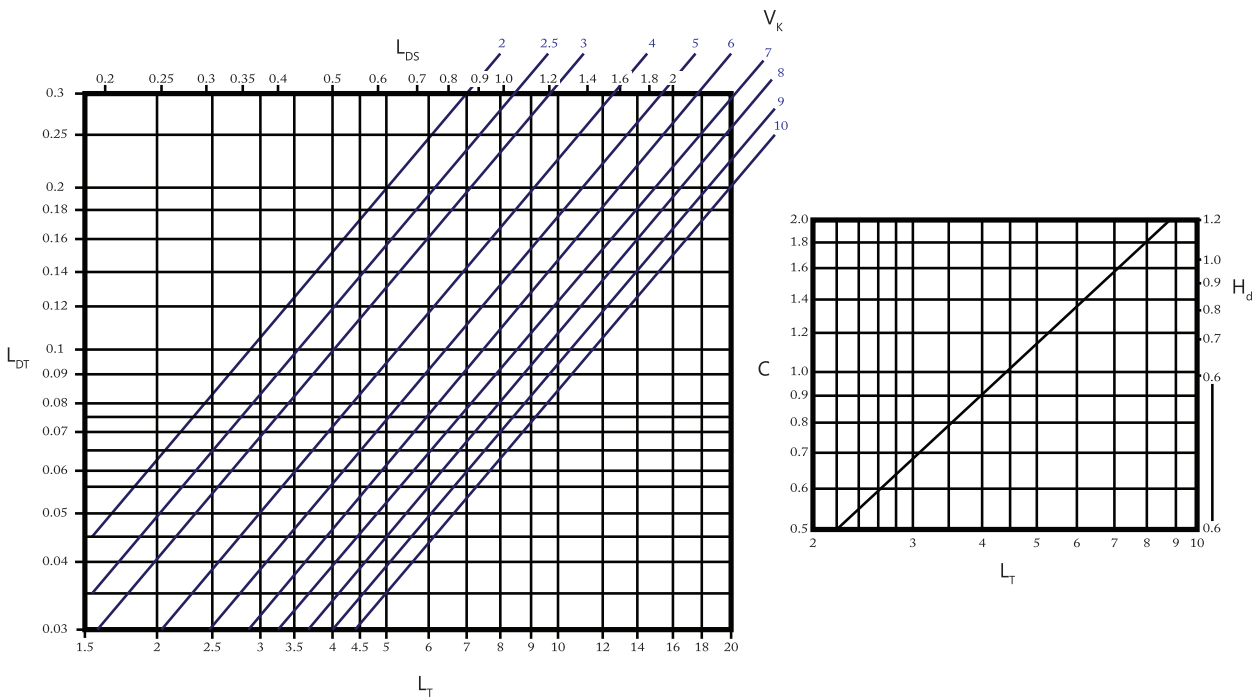
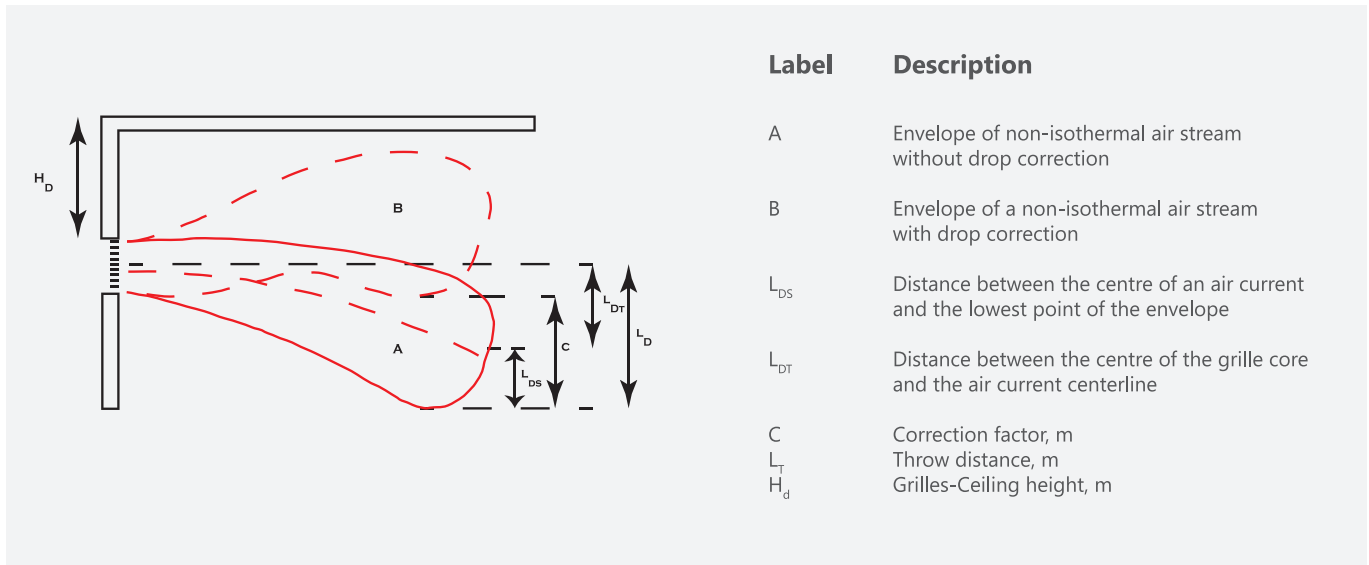

### Airstream Drop

The total drop is the maximum vertical distance between the centre of a grille core and the lowest point of a specified envelope, determined by the envelope velocity  $V_k$ .

The total drop consist of two elements :

$$L_D = L_{DS} + L_{DT}$$

### Drop Correction $L_D$

Drop correction is possible by projecting the air current upward, with supply grille having adjustable horizontal bars. The drop effect can be significantly corrected if the air is projected upward  $15^\circ$  to  $20^\circ$ , as shown in the drop correction diagram. The correction factors "C" in the diagram are only valid if the minimum distance  $H_d$  between the centre of the grille and the ceiling is maintained.

Exhaust (Single Deflection Grille)

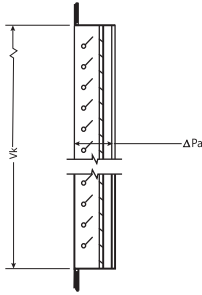

Grille Neck Size, mm	Neck Area (Eff. Area) m <sup>2</sup>	Unit Volume Flowrate, m <sup>3</sup> /hr Unit Volume Flowrate, l/s	NR25	NR35	NR40	NR50	250	300	400	500	600	800	1000	1500	2000
			70	84	112	140	168	224	280	420	560				
100 x 250	0.025 (0.010)	Face Velocity, m/s	6.9	8.3	11.1	-	-	-	-	-	-	-	-	-	-
		Total Pressure Loss, Pa	7.0	9.0	17	-	-	-	-	-	-	-	-	-	-
		Noise Rating (NR)	35	40	>50	-	-	-	-	-	-	-	-	-	-
100 x 300	0.03 (0.012)	Face Velocity, m/s	5.8	6.9	9.3	11.6	-	-	-	-	-	-	-	-	
		Total Pressure Loss, Pa	5.0	34	12	18	-	-	-	-	-	-	-	-	
		Noise Rating (NR)	27	33	46	>50	-	-	-	-	-	-	-	-	
100 x 400	0.04 (0.016)	Face Velocity, m/s	4.3	5.2	6.9	8.7	10.4	-	-	-	-	-	-	-	
		Total Pressure Loss, Pa	2.7	4.0	34	12	16	-	-	-	-	-	-	-	
		Noise Rating (NR)	20	26	37	45	>50	-	-	-	-	-	-	-	
100 x 500	0.05 (0.020)	Face Velocity, m/s	3.5	4.2	5.6	6.9	8.3	11.1	-	-	-	-	-	-	
		Total Pressure Loss, Pa	2	2.7	4.7	34	9.0	17	-	-	-	-	-	-	
		Noise Rating (NR)	<20	<20	29	36	43	>50	-	-	-	-	-	-	

\* The effective area given is to the best estimation & knowledge of Prudentaire's engineers at the point of entry.

Grille Neck Size, mm	Neck Area (Eff. Area) m <sup>2</sup>	Unit Volume Flowrate, m <sup>3</sup> /hr Unit Volume Flowrate, l/s	NR25	NR35	NR40	NR50	150	300	450	600	900	1350	2000
			2	2.7	4.7	34	9.0 <td>17</td> <td>-</td> <td>-</td> <td>-</td>	17	-	-	-		
150 x 300	0.045 (0.020)	Face Velocity, m/s	3.5	4.2	5.6	6.9	8.3	11.1	-	-	-	-	-
		Total Pressure Loss, Pa	2	2.7	4.7	34	9.0	17	-	-	-	-	-
		Noise Rating (NR)	<20	<20	29	36	43	>50	-	-	-	-	-
150 x 500	0.075 (0.033)	Face Velocity, m/s	-	-	3.4	4.2	5.1	6.7	8.4	12.6	-	-	-
		Total Pressure Loss, Pa	-	-	2	2.7	4.0	7.0	9.0	22	-	-	-
		Noise Rating (NR)	-	-	<20	21	27	37	46	>50	-	-	-
150 x 600	0.090 (0.037)	Face Velocity, m/s	-	-	3.0	3.8	4.5	6.0	7.5	11.3	-	-	-
		Total Pressure Loss, Pa	-	-	<2	2.5	3.0	5.0	8.0	18	-	-	-
		Noise Rating (NR)	-	-	<20	<20	23	35	42	>50	-	-	-
150 x 800	0.12 (0.054)	Face Velocity, m/s	-	-	-	-	3.1	4.1	5.1	7.7	10.3	-	-
		Total Pressure Loss, Pa	-	-	-	-	<2	2.7	4.0	9.0	15	-	-
		Noise Rating (NR)	-	-	-	-	<20	25	34	46	>50	-	-

Grille Neck Size, mm	Neck Area (Eff. Area) m <sup>2</sup>	Unit Volume Flowrate, m <sup>3</sup> /hr Unit Volume Flowrate, l/s	NR25	NR35	NR40	NR50	200	400	600	800	1200	1600	2000
			3.7	4.9	6.2	9.3 <td>12.3</td> <td>22</td> <td>37</td> <td>50</td> <td>65</td> <td>80</td> <td>100</td>	12.3	22	37	50	65	80	100
200 x 500	0.10 (0.045)	Face Velocity, m/s	-	-	-	-	3.7	4.9	6.2	9.3	12.3	-	-
		Total Pressure Loss, Pa	-	-	-	-	2.5	3.7	5.5	12	22	-	-
		Noise Rating (NR)	-	-	-	-	<20	28	37	50	>50	-	-
200 x 600	0.12 (0.055)	Face Velocity, m/s	-	-	-	-	-	4.1	5.1	7.7	10.3	-	-
		Total Pressure Loss, Pa	-	-	-	-	-	2.6	4.0	9.0	16	-	-
		Noise Rating (NR)	-	-	-	-	-	22	30	43	>50	-	-
200 x 800	0.16 (0.072)	Face Velocity, m/s	-	-	-	-	-	3.1	3.9	5.9	7.8	-	-
		Total Pressure Loss, Pa	-	-	-	-	-	<2	2.5	4.7	9.0	-	-
		Noise Rating (NR)	-	-	-	-	-	<20	23	34	47	-	-
200 x 1000	0.2 (0.093)	Face Velocity, m/s	-	-	-	-	-	-	3.0	4.5	6.0	-	-
		Total Pressure Loss, Pa	-	-	-	-	-	-	<2	3.0	5.0	-	-
		Noise Rating (NR)	-	-	-	-	-	-	<20	25	37	-	-

Grille Neck Size, mm	Neck Area (Eff. Area) m <sup>2</sup>	Unit Volume Flowrate, m <sup>3</sup> /hr Unit Volume Flowrate, l/s	NR25	NR35	NR40	NR50	300	600	900	1200	1500	2000
			3.1	3.9	5.9 <td>7.8</td> <td>9.0</td> <td>12.3</td> <td>16.4</td> <td>20.5</td>	7.8	9.0	12.3	16.4	20.5		
300 x 500	0.15 (0.072)	Face Velocity, m/s	-	-	-	-	3.1	3.9	5.9	7.8	9.0	-
		Total Pressure Loss, Pa	-	-	-	-	<2	2.5	4.7	9.0	12.3	-
		Noise Rating (NR)	-	-	-	-	<20	23	34	47	>50	-
300 x 600	0.18 (0.085)	Face Velocity, m/s	-	-	-	-	-	3.3	5.0	6.6	8.2	-
		Total Pressure Loss, Pa	-	-	-	-	-	<2	3.8	6.2	8.2	-
		Noise Rating (NR)	-	-	-	-	-	<20	30	43	56	-
300 x 800	0.24 (0.114)	Face Velocity, m/s	-	-	-	-	-	-	3.7	4.9	6.1	-
		Total Pressure Loss, Pa	-	-	-	-	-	-	2.5	3.7	4.9	-
		Noise Rating (NR)	-	-	-	-	-	-	20	32	43	-
300 x 1000	0.3 (0.144)	Face Velocity, m/s	-	-	-	-	-	-	-	3.9	5.2	-
		Total Pressure Loss, Pa	-	-	-	-	-	-	-	3.0	4.5	6.0
		Noise Rating (NR)	-	-	-	-	-	-	-	25	37	50

## Single Deflection Grille

### ALUMINIUM TECHNICAL SPECIFICATION

#### Frame Construction

1. Frame to be in extruded aluminium. Frame thickness should be in minimum 1.2mm thick, unless otherwise stated.
2. The margin to be in 28mm from the neck height to the edge.
3. Frame height to be in 50mm.
4. The corner of the frame should be pressed with a 90° corner piece to ensure the frames are in 90°.
5. Removable core designs are available upon request.

#### Vanes Construction

1. Vanes to be in extruded aluminium.
2. Vanes to be in 1.0mm thick aerofoil design to provide a better air pattern.
3. Vanes are arranged with single layer only and able to be adjusted individually.
4. Vanes pitch to be in 20mm.

#### Finishing

1. White powder coated, oven baked as standard. RAL 9010 SG or HY 1001/A127. Others available upon request.

#### Performance

1. Free area of the grill to be in 86%.
2. Vanes angle should be with pre-set 90° and adjustable individually.
3. Single Deflection Grilles are designed to be installed as wall mounted as an exhaust or return opening.

### GALVANIZED STEEL TECHNICAL SPECIFICATION

#### Frame Construction

1. Frame to be in galvanized steel. Frame thickness should be in minimum 0.6mm thick, unless otherwise stated.
2. The margin to be in 30mm from the neck height to the edge.
3. Frame height to be in 50mm.
4. Removable core designs are available upon request.

#### Vanes Construction

1. Vanes to be in extruded aluminium.
2. Vanes to be in 1.0mm thick aerofoil design to provide a better air pattern.
3. Vanes are arranged with single layer only and able to be adjusted individually.
4. Vanes pitch to be in 20mm.

#### Finishing

1. White powder coated, oven baked as standard. RAL 9010 SG or HY 1001/A127. Others available upon request.

#### Performance

1. Free area of the grill to be in 86%.
2. Vanes angle should be with pre-set 90° and adjustable individually.
3. Single Deflection Grilles are designed to be installed as wall mounted as an exhaust or return opening.

## Double Deflection Grille

### ALUMINIUM TECHNICAL SPECIFICATION

#### Frame Construction

1. Frame to be in extruded aluminium. Frame thickness should be in minimum 1.2mm thick, unless otherwise stated.
2. The margin to be in 28mm from the neck height to the edge.
3. Frame height to be in 50mm.
4. The corner of the frame should be pressed with a 90° corner piece to ensure the frames are in 90°.
5. Removable core designs are available upon request.

#### Vanes Construction

1. Vanes to be in extruded aluminium.
2. Vanes to be in 1.0mm thick aerofoil design to provide a better air pattern.
3. Vanes are arranged with double layer and able to be adjusted 4 directional individually.
4. Vanes pitch to be in 20mm.

#### Finishing

1. White powder coated, oven baked as standard. RAL 9010 SG or HY 1001/A127. Others available upon request.

#### Performance

1. Free area of the grill to be in 74%.
2. Vanes angle should be with pre-set 90° and adjustable individually to achieved to required air pattern.
3. Double Deflection Grilles are designed to be installed as wall mounted as a supply air or return air opening.

### GALVANIZED STEEL TECHNICAL SPECIFICATION

#### Frame Construction

1. Frame to be in galvanized steel. Frame thickness should be in minimum 0.6mm thick, unless otherwise stated.
2. The margin to be in 30mm from the neck height to the edge.
3. Frame height to be in 50mm.
4. Removable core designs are available upon request.

#### Vanes Construction

1. Vanes to be in extruded aluminium.
2. Vanes to be in 1.0mm thick aerofoil design to provide a better air pattern.
3. Vanes are arranged with Double layer and able to be adjusted 4 directional individually.
4. Vanes pitch to be in 20mm.

#### Finishing

1. White powder coated, oven baked as standard. RAL 9010 SG or HY 1001/A127. Others available upon request.

#### Performance

1. Free area of the grill to be in 74%.
2. Vanes angle should be with pre-set 90° and adjustable individually to achieved required air throw pattern.
3. Double Deflection Grilles are designed to be installed as wall mounted as a supply air or return air opening.

## AVAILABLE TYPES

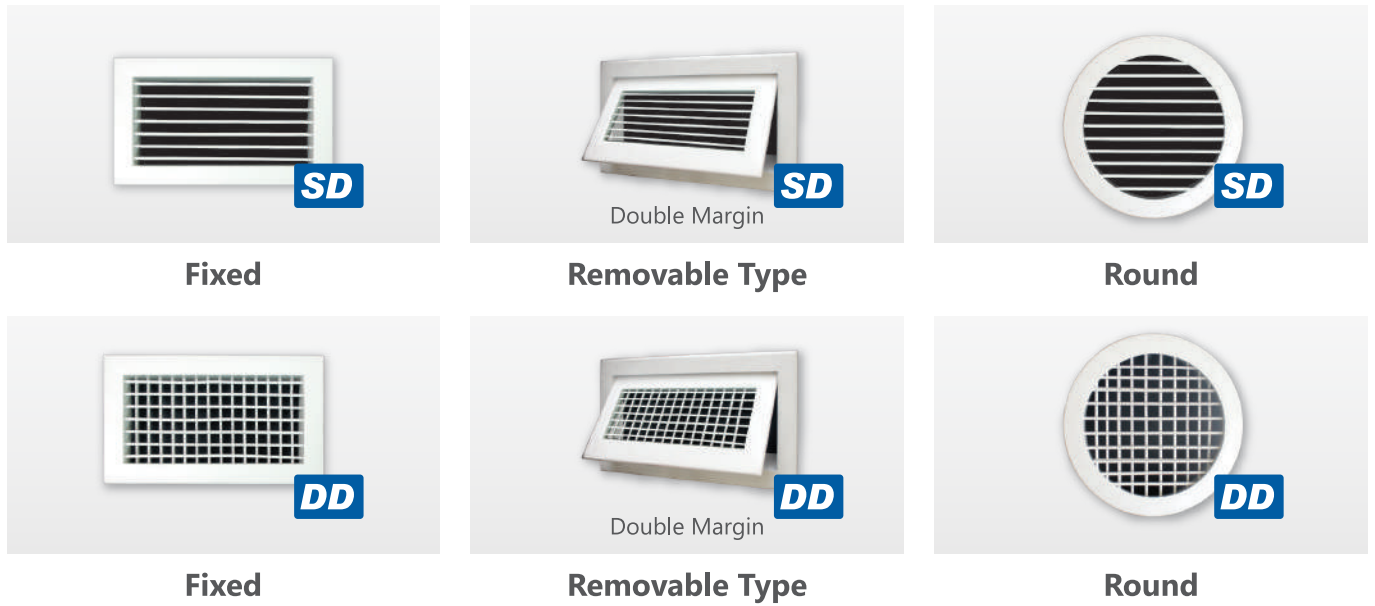

## GRILLE + ACCESSORIES COMBINATION

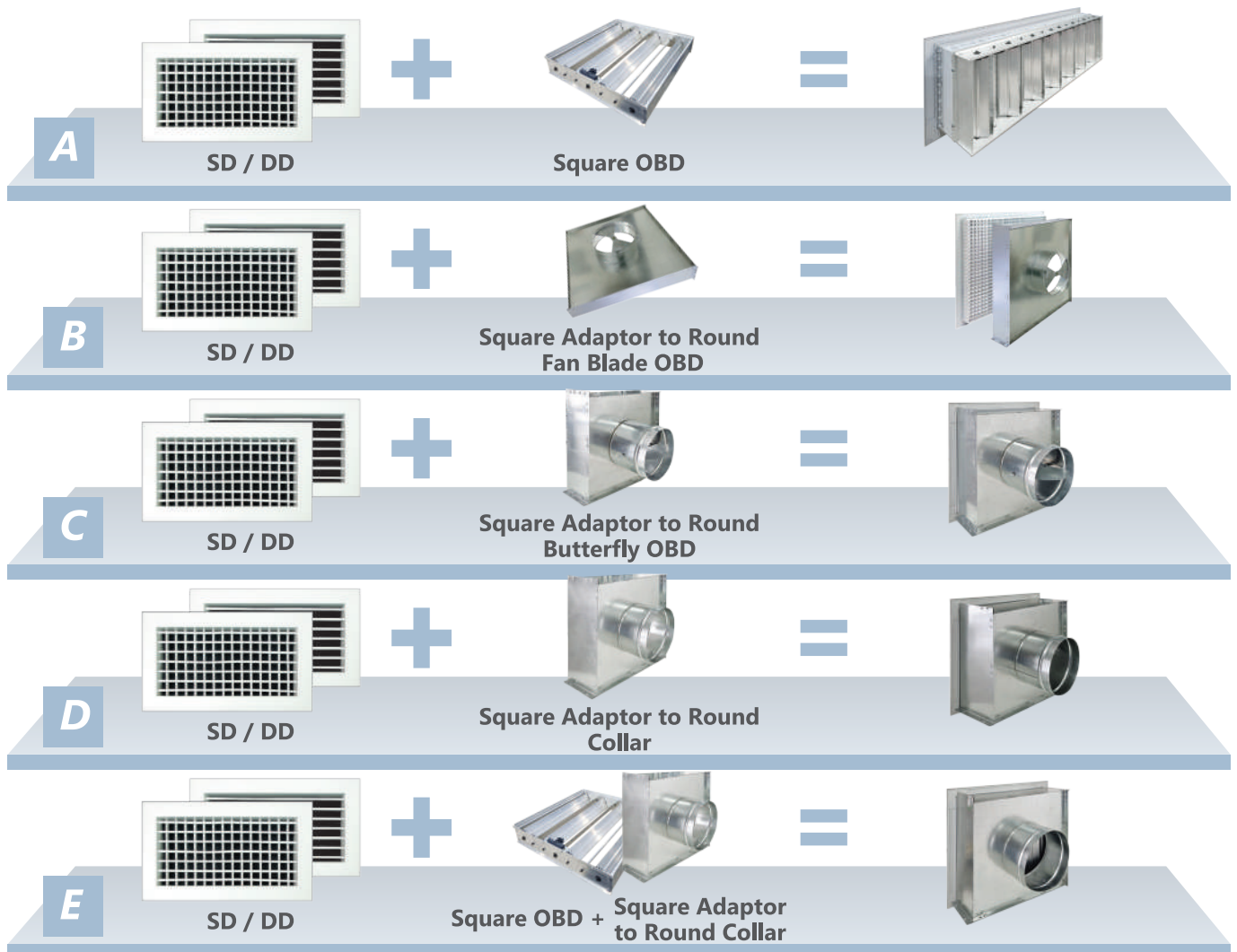

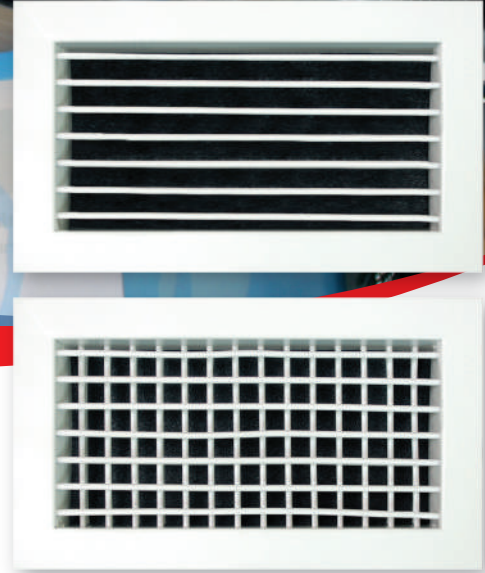







# **SD & DD**

## *Single & Double Deflection Grille*

### Products Range

- Grilles  ◀
- Diffusers 
- Dampers 
- Fire & Smoke Protection 
- VAV 
- Others 
- Accessories 



**Prudent Aire Engineering Sdn Bhd** 657301-P  
 Lot 2102, Jalan KPB12, Off Jalan Suria Park 1, Kg Baru Balakong,  
 43300 Seri Kembangan, Selangor Darul Ehsan, Malaysia  
 Tel : +603-9100 3858 (HL) / 9101 3869 / 9101 5868  
 Fax : +603-9100 4868 Email : sales@prudentaire.com

[www.prudentaire.com](http://www.prudentaire.com)